

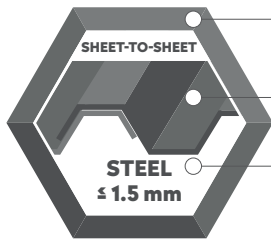

SELF-DRILLING METAL SCREW PRO

APPLICATION



SS SUS410

Sheet-to-sheet

Steel ≤ 1,5 mm

SPECIFICATION

- 1 Head style 8 mm
- 2 Washer diameter standard 16 mm
- 3 EPDM bond seal
- 4 Thread for substructure steel ≤ 1,5 mm
- 5 Sharp drilling point

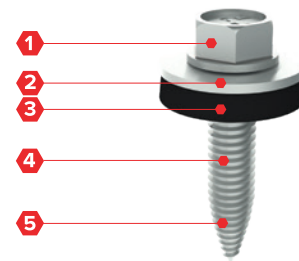

OPTIONS

- 1 Powder coated in any desired colour
- 2 Washer diameter 16 or 19 mm

SECTION

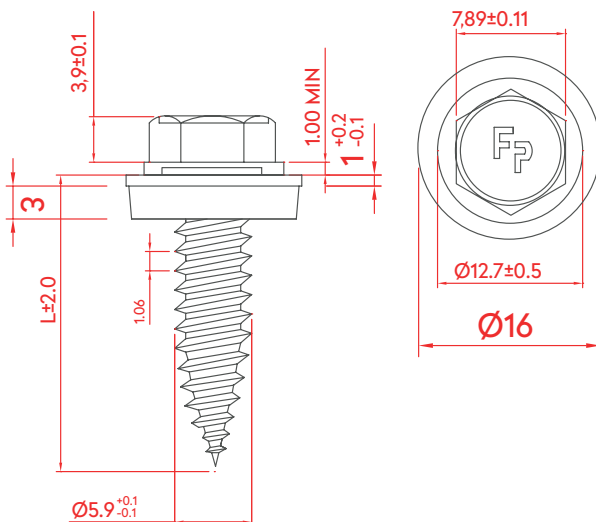

STITCHING SCREWS - STEEL ≤ 1,5 MM - SS SUS410

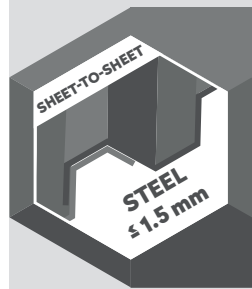

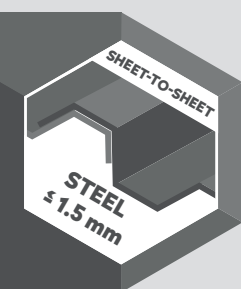
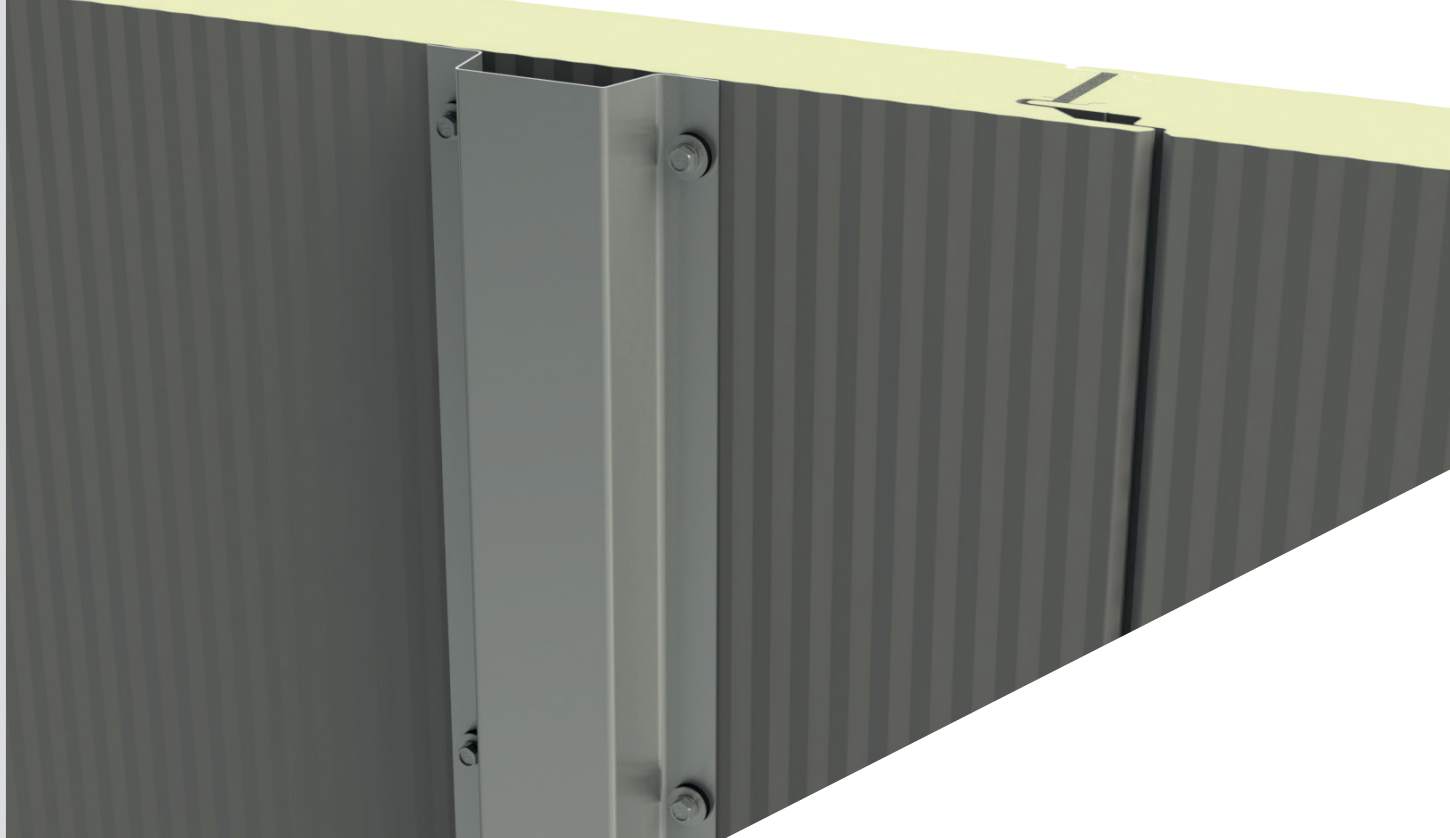

SCREW POSITION

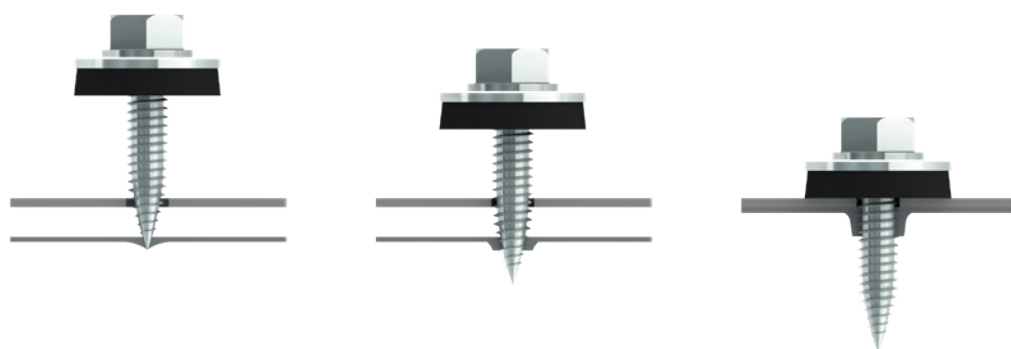

ORDER INFORMATION

Product	Size	Packaging	Article code
Self-Drilling metal screw PRO 6,0 x L	25 mm	250 pcs/box	2003006002516

CERTIFICATES



QUALITY
CONFIRMED



More information on materials, application, specific properties and certification can be found in chapter 10.

SELF-DRILLING METAL SCREW PRO 6,0 X L, PRESSED RING

Materials	
Screw	SS 1.4006 (SUS410) - conform EN3506
Washer	SS 1.4301 (A2) - conform EN3506
Material A (t_I)	Steel quality S280GD, S320GD and S350GD - conform EN 10346
Material B (t_{II})	Steel quality S235, S280GD, S320GD and S350GD - conform EN 10346
Drilling capacity	$\leq 1,5$ mm





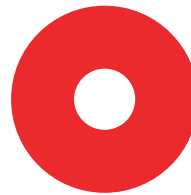
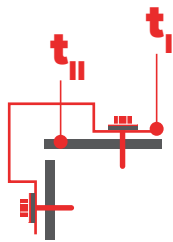

PRESSED RING

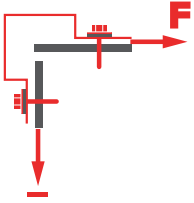
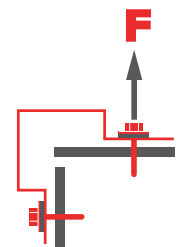
		t_{N1} [mm]	t_{II} [mm]				
			0,40	0,50	0,55	0,60	0,63
 $V_{R,k}$ [kN]	0,40	1,49	1,49	1,49	1,49	1,49	1,49
	0,50	1,49	1,90	1,90	1,90	1,90	1,90
	0,55	1,49	1,90	2,07	2,07	2,07	2,07
	0,60	1,49	1,90	2,07	2,24	2,24	2,24
	0,63	1,49	1,90	2,07	2,24	2,35	2,35
	0,75	1,49	1,90	2,07	2,24	2,35	2,76
 $N_{R,k}$ [kN]	0,40	0,70	0,91	1,05	1,08	1,08	1,08
	0,50	0,70	0,91	1,05	1,22	1,23	1,23
	0,55	0,70	0,91	1,05	1,22	1,23	1,42
	0,60	0,70	0,91	1,05	1,22	1,23	1,48
	0,63	0,70	0,91	1,05	1,22	1,23	1,48
	0,75	0,70	0,91	1,05	1,22	1,23	1,48



Note

1. Above mentioned values are characteristic values
2. To determine the design value we advise to apply a material factor of $\gamma_m = 1,33$.
3. You can find further information and calculation examples on page 10.1.7.

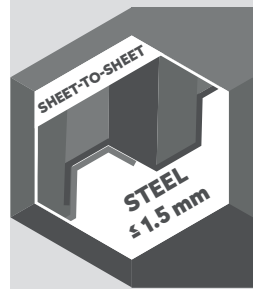
STITCHING SCREWS - STEEL $\leq 1,5$ MM - SS SUS410



SELF-DRILLING METAL SCREW PRO 6,0 X L, WASHER DIAMETER Ø 16,0 mm

Materials		
Screw	SS 1.4006 (SUS410) - conform EN3506	 
Washer	SS 1.4301 (A2) - conform EN3506	
Material A (t_{II})	Steel quality S280GD, S320GD and S350GD - conform EN 10346	
Material B (t_{II})	Steel quality S235, S280GD, S320GD and S350GD - conform EN 10346	
Drilling capacity	≤ 1,5 mm	

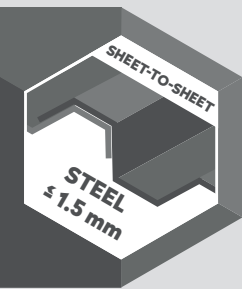
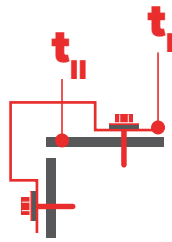

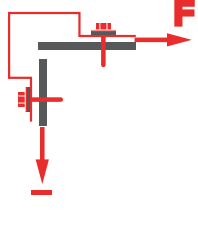
		t_{NI} [mm]	t_{II} [mm]					
			0,40	0,50	0,55	0,60	0,63	0,75
 $V_{R,k}$ [kN]	0,40	1,49	1,49	1,49	1,49	1,49	1,49	
	0,50	1,49	1,90	1,90	1,90	1,90	1,90	
	0,55	1,49	1,90	2,07	2,07	2,07	2,07	
	0,60	1,49	1,90	2,07	2,24	2,24	2,24	
	0,63	1,49	1,90	2,07	2,24	2,35	2,35	
	0,75	1,49	1,90	2,07	2,24	2,35	2,76	
 $N_{R,k}$ [kN]	0,40	0,70	0,91	1,05	1,22	1,23	1,48	
	0,50	0,70	0,91	1,05	1,22	1,23	1,48	
	0,55	0,70	0,91	1,05	1,22	1,23	1,48	
	0,60	0,70	0,91	1,05	1,22	1,23	1,48	
	0,63	0,70	0,91	1,05	1,22	1,23	1,48	
	0,75	0,70	0,91	1,05	1,22	1,23	1,48	

Note

1. Above mentioned values are characteristic values
2. To determine the design value we advise to apply a material factor of $\gamma_m = 1,33$.
3. You can find further information and calculation examples on page 10.1.7.

SELF-DRILLING METAL SCREW PRO 6,0 X L, WASHER DIAMETER Ø 19,0 mm

Materials	
Screw	SS 1.4006 (SUS410) - conform EN3506
Washer	SS 1.4301 (A2) - conform EN3506
Material A (t_I)	Steel quality S280GD, S320GD and S350GD - conform EN 10346
Material B (t_{II})	Steel quality S235, S280GD, S320GD and S350GD - conform EN 10346
Drilling capacity	≤ 1,5 mm





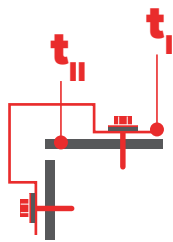

		t_{N1} [mm]	t_{II} [mm]				
			0,40	0,50	0,55	0,60	0,63
 $V_{R,k}$ [kN]	0,40	1,49	1,49	1,49	1,49	1,49	1,49
	0,50	1,49	1,90	1,90	1,90	1,90	1,90
	0,55	1,49	1,90	2,07	2,07	2,07	2,07
	0,60	1,49	1,90	2,07	2,24	2,24	2,24
	0,63	1,49	1,90	2,07	2,24	2,35	2,35
	0,75	1,49	1,90	2,07	2,24	2,35	2,76
 $N_{R,k}$ [kN]	0,40	0,70	0,91	1,05	1,22	1,23	1,48
	0,50	0,70	0,91	1,05	1,22	1,23	1,48
	0,55	0,70	0,91	1,05	1,22	1,23	1,48
	0,60	0,70	0,91	1,05	1,22	1,23	1,48
	0,63	0,70	0,91	1,05	1,22	1,23	1,48
	0,75	0,70	0,91	1,05	1,22	1,23	1,48

Note

1. Above mentioned values are characteristic values
2. To determine the design value we advise to apply a material factor of $\gamma_m = 1,33$.
3. You can find further information and calculation examples on page 10.1.7.

STITCHING SCREWS - STEEL ≤ 1,5 mm - SS SUS410

