

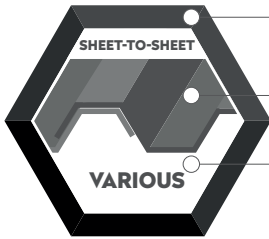

BLIND RIVET TRE-GO ALUMINIUM / ALUMINIUM

APPLICATION



Aluminium / Aluminium

Sheet-to-sheet

Various

SPECIFICATION

- 1 Mandrel head (aluminium)
- 2 Rivet body (aluminium)
- 3 Nail head (aluminium)
- 4 Mandrel (aluminium)

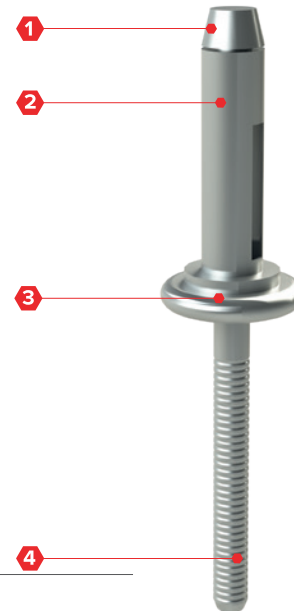

OPTIONS

- 1 Powder coated in any desired colour

SECTION

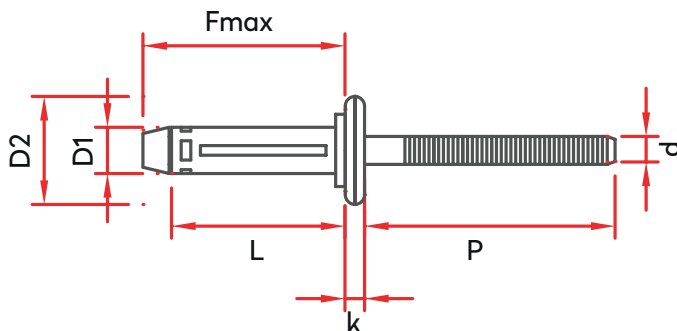

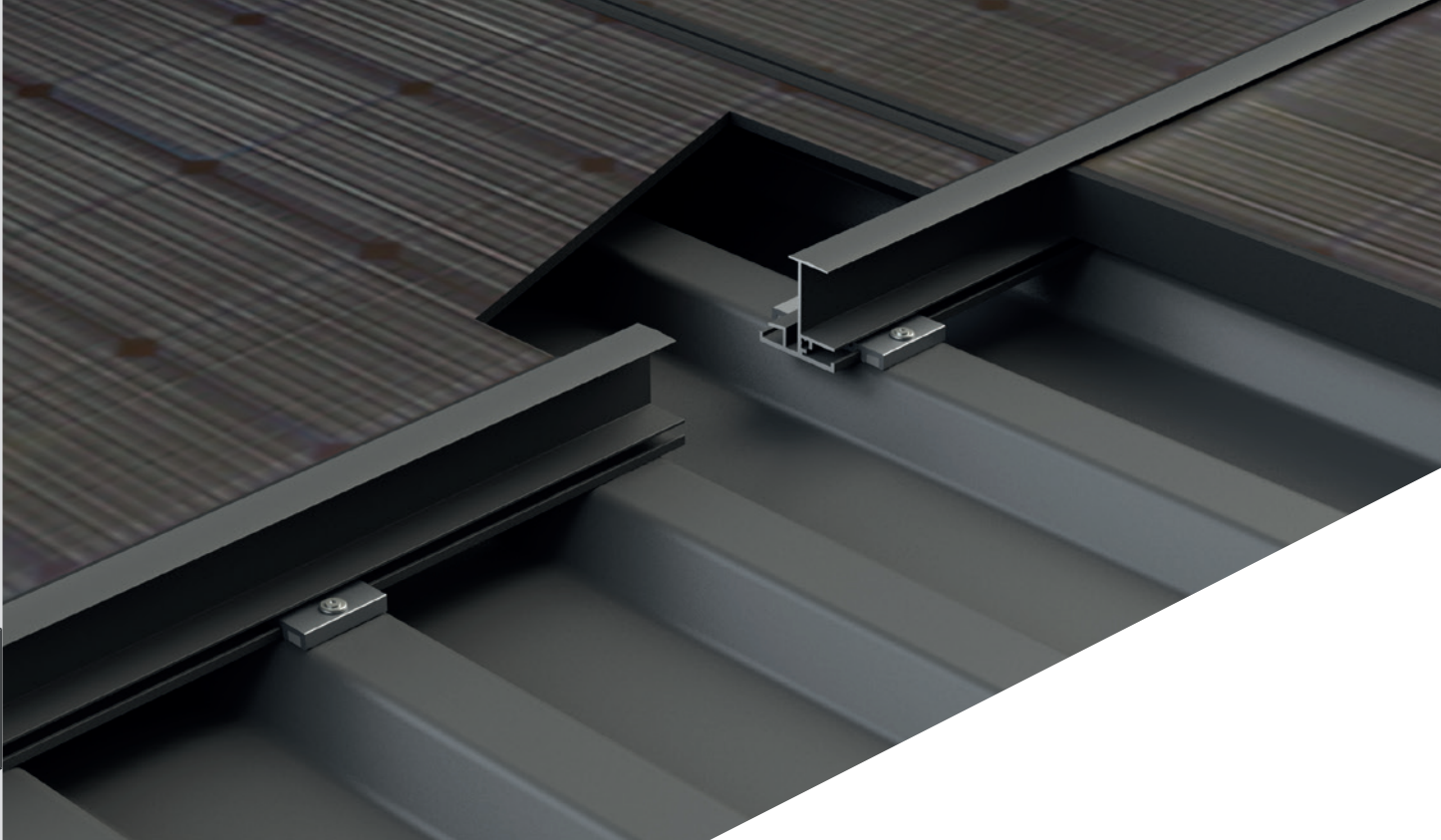
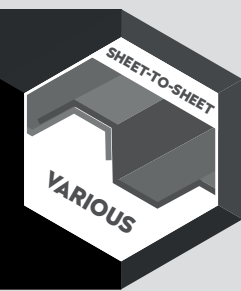

APPLICATION

Using the table below you can easily determine the sufficient blind rivet length.

Size	Thickness (mm)														Article code
	0,5	1,0	2,0	3,0	4,0	5,0	6,0	7,0	8,0	9,0	10,0	12,0	14,0	16,0	
6,3 x 23,4 mm															20150063234



BLIND RIVET TRE-GO ALUMINIUM / ALUMINIUM

DIMENSIONS

Product	D1	D2	d	P	k	L	Pre-drill
Blind rivet, Tre-go, 6,3 x 23,4 mm, AL/AL	6,3	14,4	3,9	>25,4	3,8	23,4	6,4-6,6 mm

MECHANICAL PROPERTIES

Product	Shear force	Tensile strength
Blind rivet, Tre-go, 6,3 x 23,4 mm, AL/AL	3780 N	2250 N

ORDER INFORMATION

Product	EPDM Washer	Size	Packaging	Article code
Blind rivet, Tre-go, AL/AL	Yes	6,3 x 23,4 mm	2000 pcs./box	20150063234

Other types and measurements available on request.

CERTIFICATES



QUALITY
CONFIRMED



