

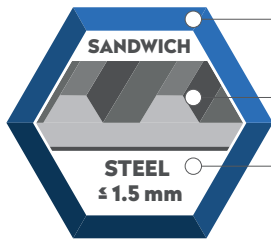

SANDWICH PANEL SCREW DP2

APPLICATION



Galvanised

Sandwich Panels

Steel ≤ 1,5 mm

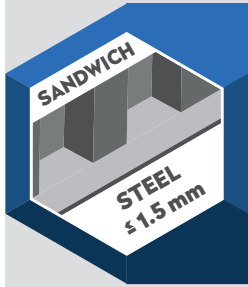

SPECIFICATION

- 1 Head style 5/16" (8 mm)
- 2 Washer diameter standard 19 mm
- 3 Galvanised EPDM bond seal
- 4 Support thread
- 5 Thread for substructure steel ≤ 1,5 mm
- 6 Drilling point 2 reduced

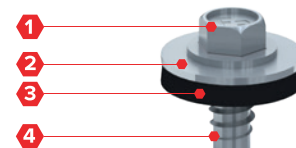

OPTIONS

- 1 Powder coated in any desired RAL colour
- 2 Washer diameter 16 or 22 mm

SECTION

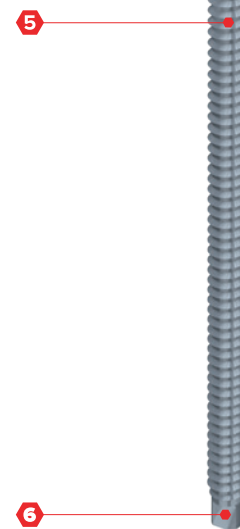
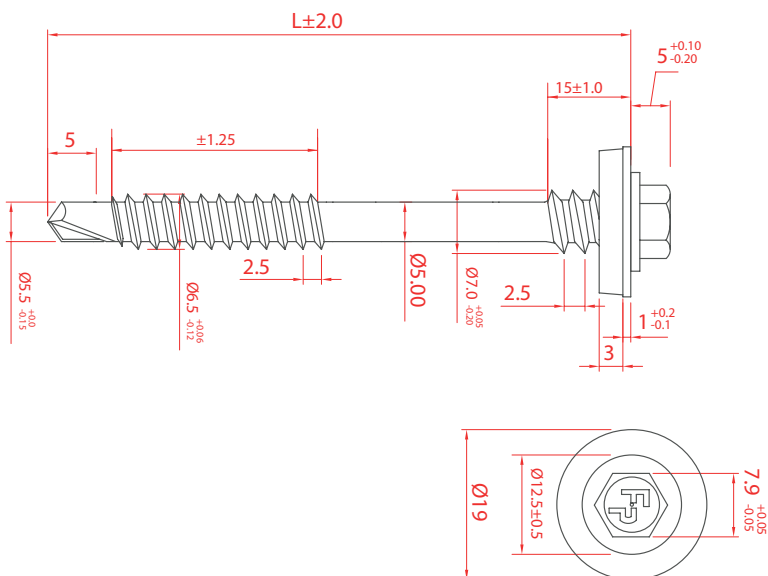

SANDWICH PANELS - STEEL ≤ 1,5 MM - GALVANISED

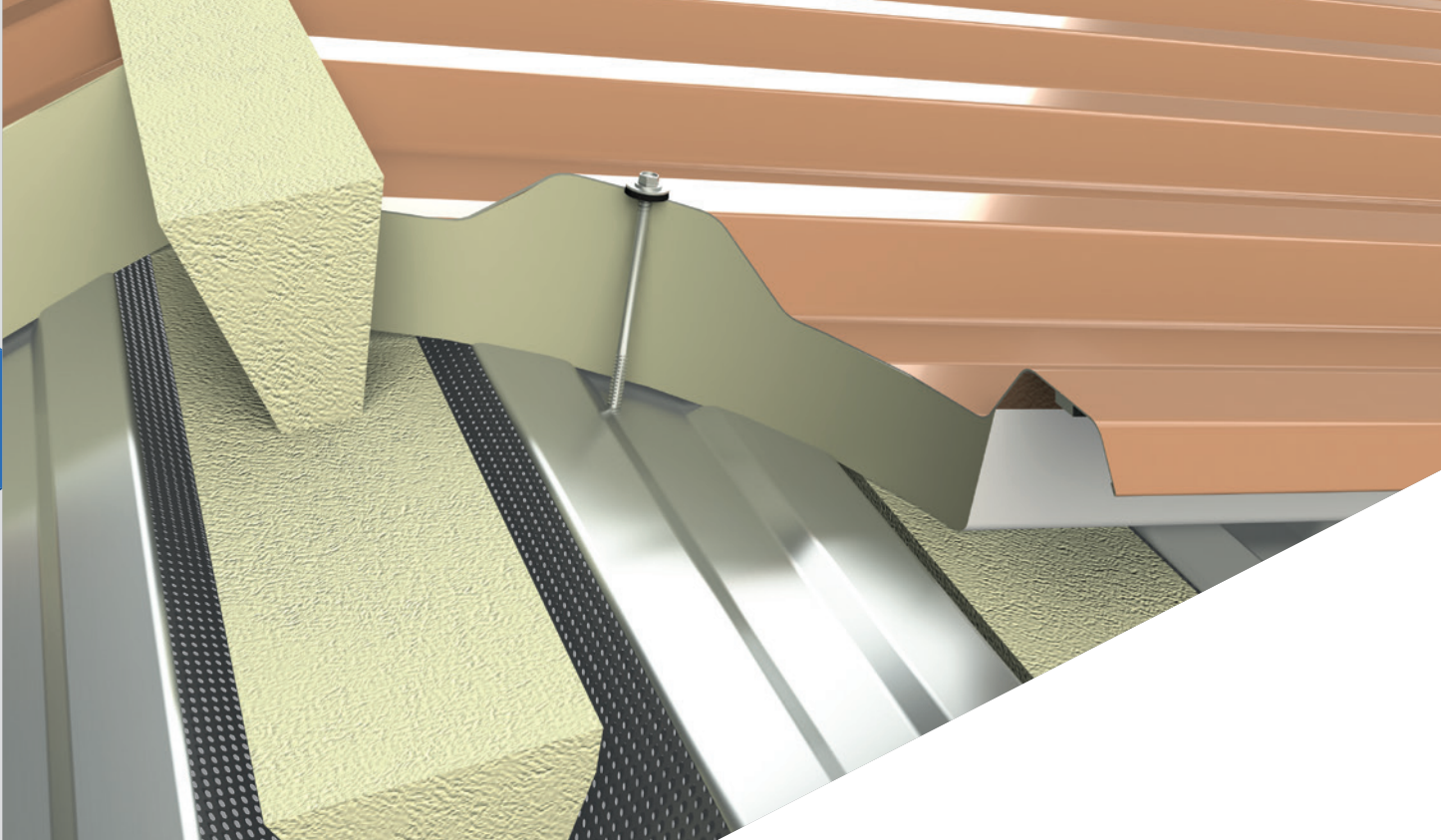
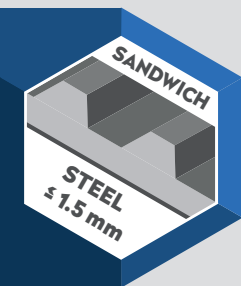

SANDWICH PANELS - STEEL ≤ 1,5 MM - GALVANISED

APPLICATION

Using the table below you can easily determine the sufficient screw length.

Size	Insulation thickness (mm)													Article code
	20	40	60	80	100	120	140	160	180	200	220	240	260	
6,3/7,0 x 75 mm	■	0 - 25 mm												1004026307519
6,3/7,0 x 100 mm		■	25 - 50 mm											1004026310019
6,3/7,0 x 125 mm			■	50 - 75 mm									1004026312519	
6,3/7,0 x 145 mm				■	75 - 95 mm							1004026314519		
6,3/7,0 x 165 mm					■	95 - 115 mm					1004026316519			
6,3/7,0 x 185 mm						■	115 - 135 mm				1004026318519			
6,3/7,0 x 205 mm							■	135 - 155 mm			1004026320519			
6,3/7,0 x 225 mm								■	155 - 175 mm			1004026322519		
6,3/7,0 x 245 mm									■	175 - 195 mm		1004026324519		
6,3/7,0 x 265 mm										■	175 - 215 mm		1004026326519	
6,3/7,0 x 300 mm											■	215 - 250 mm		1004026330019



More information on materials, application, specific properties and certification can be found in chapter 10.

ORDER INFORMATION

Product	Size (L)	Packaging	Article code
Sandwich Panel Screw 6,3/7,0 x 75 – DP2	75 mm	100 pcs/box	1004026307519
Sandwich Panel Screw 6,3/7,0 x 100 – DP2	100 mm	100 pcs/box	1004026310019
Sandwich Panel Screw 6,3/7,0 x 125 – DP2	125 mm	100 pcs/box	1004026312519
Sandwich Panel Screw 6,3/7,0 x 145 – DP2	145 mm	100 pcs/box	1004026314519
Sandwich Panel Screw 6,3/7,0 x 165 – DP2	165 mm	100 pcs/box	1004026316519
Sandwich Panel Screw 6,3/7,0 x 185 – DP2	185 mm	100 pcs/box	1004026318519
Sandwich Panel Screw 6,3/7,0 x 205 – DP2	205 mm	100 pcs/box	1004026320519
Sandwich Panel Screw 6,3/7,0 x 225 – DP2	225 mm	100 pcs/box	1004026322519
Sandwich Panel Screw 6,3/7,0 x 245 – DP2	245 mm	100 pcs/box	1004026324519
Sandwich Panel Screw 6,3/7,0 x 265 – DP2	265 mm	100 pcs/box	1004026326519
Sandwich Panel Screw 6,3/7,0 x 300 – DP2	300 mm	100 pcs/box	1004026330019

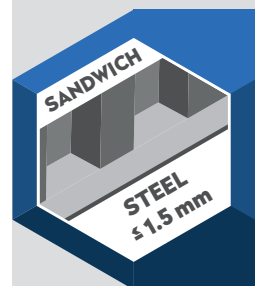



SANDWICH PANELS - STEEL ≤ 1,5 MM - GALVANISED

CERTIFICATES

QUALITY
CONFIRMED

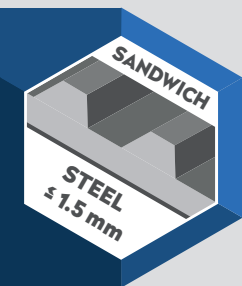

SANDWICH PANEL SCREW 6,3/7,0 X L – DP2, WASHER DIAMETER Ø 16,0 MM

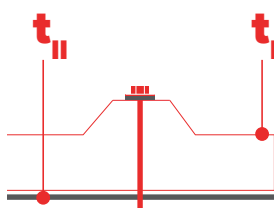

Materials		 
Screw	Galvanised steel	
Washer	Galvanised steel	
Material A (t_I)	S280GD, S320GD and S350GD conform EN 10346	
Material B (t_{II})	S235 conform EN 10025-2, S280GD, S320GD and S350GD conform EN 10346	
Drilling capacity	Steel $\leq 1,5$ mm	



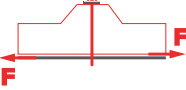

SANDWICH PANELS - STEEL $\leq 1,5$ MM - GALVANISED

		t_{NI} [mm]	t_{II} [mm]										
			0,40	0,50	0,55	0,63	0,75	0,88	1,00	1,13	1,25	1,50	2,00
	$V_{R,k}$ [kN]	0,40	1,48	1,48	1,48	1,48	1,48	1,48	1,48	1,48	1,48	1,48	1,48
		0,50	1,48	2,32	2,32	2,32	2,32	2,32	2,32	2,32	2,32	2,32	2,32
		0,55	1,48	2,32	2,35	2,35	2,35	2,35	2,35	2,35	2,35	2,35	2,35
		0,63	1,48	2,32	2,35	2,39	2,39	2,39	2,39	2,39	2,39	2,39	2,39
		0,75	1,48	2,32	2,35	2,39	2,46	2,46	2,46	2,46	2,46	2,46	2,46
		0,88	1,48	2,32	2,35	2,39	2,46	2,46	2,46	2,46	2,46	2,46	2,46
		1,00	1,48	2,32	2,35	2,39	2,46	2,46	2,46	2,46	2,46	2,46	2,46
	$N_{R,k}$ [kN]	0,40	0,42	0,74	0,76	0,78	0,83	1,13	1,28	1,33	1,33	1,33	
		0,50	0,42	0,74	0,76	0,78	0,83	1,13	1,28	1,45	1,61	1,97	
		0,55	0,42	0,74	0,76	0,78	0,83	1,13	1,28	1,45	1,61	1,97	
		0,63	0,42	0,74	0,76	0,78	0,83	1,13	1,28	1,45	1,61	1,97	
		0,75	0,42	0,74	0,76	0,78	0,83	1,13	1,28	1,45	1,61	1,97	
		0,88	0,42	0,74	0,76	0,78	0,83	1,13	1,28	1,45	1,61	1,97	
		1,00	0,42	0,74	0,76	0,78	0,83	1,13	1,28	1,45	1,61	1,97	
	u [mm]	40	-	-	-	-	8,0	8,0	8,0	8,0	10,0	10,0	
		50	-	-	-	-	10,0	10,0	10,0	10,0	10,0	12,5	12,5
		60	-	-	-	-	12,0	12,0	12,0	12,0	12,0	15,0	15,0
		80	-	-	-	-	16,0	16,0	16,0	16,0	16,0	20,0	20,0
		100	-	-	-	-	20,0	20,0	20,0	20,0	20,0	25,0	25,0
		120	-	-	-	-	24,0	24,0	24,0	24,0	24,0	30,0	30,0
		≥ 160	-	-	-	-	32,0	32,0	32,0	32,0	32,0	40,0	40,0

Note

1. Above mentioned values are characteristic values
2. To determine the design value we advise to apply a material factor of $\gamma_m = 1,33$.
3. You can find further information and calculation examples on page 10.1.7

SANDWICH PANEL SCREW 6,3/7,0 X L – DP2, WASHER DIAMETER Ø 19,0 MM

Materials		  QUALITY CONFIRMED
Screw	Galvanised steel	
Washer	Galvanised steel	
Material A (t_{II})	S280GD, S320GD and S350GD conform EN 10346	
Material B (t_{II})	S235 conform EN 10025-2, S280GD, S320GD and S350GD conform EN 10346	
Drilling capacity	Steel $\leq 1,5$ mm	

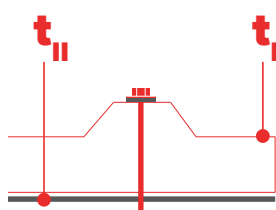
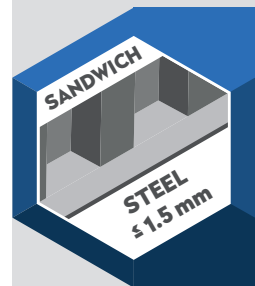

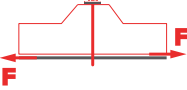
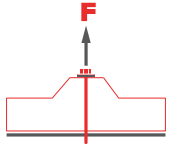
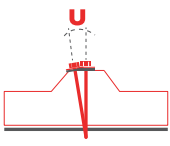
		t_{N1} [mm]	t_{II} [mm]										
			0,40	0,50	0,55	0,63	0,75	0,88	1,00	1,13	1,25	1,50	2,00
	$V_{R,k}$ [kN]	0,40	1,48	1,48	1,48	1,48	1,48	1,48	1,48	1,48	1,48	1,48	1,48
		0,50	1,48	2,32	2,32	2,32	2,32	2,32	2,32	2,32	2,32	2,32	2,32
		0,55	1,48	2,32	2,35	2,35	2,35	2,35	2,35	2,35	2,35	2,35	2,35
		0,63	1,48	2,32	2,35	2,39	2,39	2,39	2,39	2,39	2,39	2,39	2,39
		0,75	1,48	2,32	2,35	2,39	2,46	2,46	2,46	2,46	2,46	2,46	2,46
		0,88	1,48	2,32	2,35	2,39	2,46	2,46	2,46	2,46	2,46	2,46	2,46
		1,00	1,48	2,32	2,35	2,39	2,46	2,46	2,46	2,46	2,46	2,46	2,46
	$N_{R,k}$ [kN]	0,40	0,42	0,74	0,76	0,78	0,83	1,13	1,28	1,45	1,50	1,50	1,50
		0,50	0,42	0,74	0,76	0,78	0,83	1,13	1,28	1,45	1,61	1,97	1,97
		0,55	0,42	0,74	0,76	0,78	0,83	1,13	1,28	1,45	1,61	1,97	1,97
		0,63	0,42	0,74	0,76	0,78	0,83	1,13	1,28	1,45	1,61	1,97	1,97
		0,75	0,42	0,74	0,76	0,78	0,83	1,13	1,28	1,45	1,61	1,97	1,97
		0,88	0,42	0,74	0,76	0,78	0,83	1,13	1,28	1,45	1,61	1,97	1,97
		1,00	0,42	0,74	0,76	0,78	0,83	1,13	1,28	1,45	1,61	1,97	1,97
	u [mm]	40	-	-	-	-	8,0	8,0	8,0	8,0	8,0	10,0	10,0
		50	-	-	-	-	10,0	10,0	10,0	10,0	10,0	12,5	12,5
		60	-	-	-	-	12,0	12,0	12,0	12,0	12,0	15,0	15,0
		80	-	-	-	-	16,0	16,0	16,0	16,0	16,0	20,0	20,0
		100	-	-	-	-	20,0	20,0	20,0	20,0	20,0	25,0	25,0
		120	-	-	-	-	24,0	24,0	24,0	24,0	24,0	30,0	30,0
		≥ 160	-	-	-	-	32,0	32,0	32,0	32,0	32,0	40,0	40,0



Note

1. Above mentioned values are characteristic values
2. To determine the design value we advise to apply a material factor of $\gamma_m = 1,33$.
3. You can find further information and calculation examples on page 10.1.7

SANDWICH PANELS - STEEL $\leq 1,5$ MM - GALVANISED

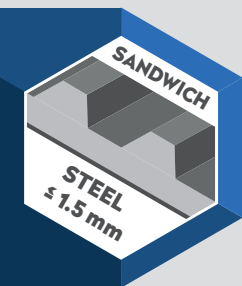

SANDWICH PANEL SCREW 6,3/7,0 X L – DP2, WASHER DIAMETER Ø 22,0 MM

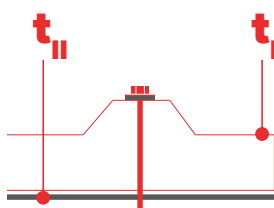

Materials		 
Screw	Galvanised steel	
Washer	Galvanised steel	
Material A (t_I)	S280GD, S320GD and S350GD conform EN 10346	
Material B (t_{II})	S235 conform EN 10025-2, S280GD, S320GD and S350GD conform EN 10346	
Drilling capacity	Steel $\leq 1,5$ mm	

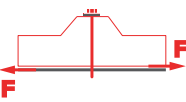

SANDWICH PANELS - STEEL $\leq 1,5$ MM - GALVANISED

		t_{NI} [mm]	t_{II} [mm]											
			0,40	0,50	0,55	0,63	0,75	0,88	1,00	1,13	1,25	1,50	2,00	
	$V_{R,k}$ [kN]	0,40	1,48	1,48	1,48	1,48	1,48	1,48	1,48	1,48	1,48	1,48	1,48	
		0,50	1,48	2,32	2,32	2,32	2,32	2,32	2,32	2,32	2,32	2,32	2,32	
		0,55	1,48	2,32	2,35	2,35	2,35	2,35	2,35	2,35	2,35	2,35	2,35	
		0,63	1,48	2,32	2,35	2,39	2,39	2,39	2,39	2,39	2,39	2,39	2,39	
		0,75	1,48	2,32	2,35	2,39	2,46	2,46	2,46	2,46	2,46	2,46	2,46	
		0,88	1,48	2,32	2,35	2,39	2,46	2,46	2,46	2,46	2,46	2,46	2,46	
		1,00	1,48	2,32	2,35	2,39	2,46	2,46	2,46	2,46	2,46	2,46	2,46	
	$N_{R,k}$ [kN]	0,40	0,42	0,74	0,76	0,78	0,83	1,13	1,28	1,45	1,61	1,71	1,71	
		0,50	0,42	0,74	0,76	0,78	0,83	1,13	1,28	1,45	1,61	1,97	1,97	
		0,55	0,42	0,74	0,76	0,78	0,83	1,13	1,28	1,45	1,61	1,97	1,97	
		0,63	0,42	0,74	0,76	0,78	0,83	1,13	1,28	1,45	1,61	1,97	1,97	
		0,75	0,42	0,74	0,76	0,78	0,83	1,13	1,28	1,45	1,61	1,97	1,97	
		0,88	0,42	0,74	0,76	0,78	0,83	1,13	1,28	1,45	1,61	1,97	1,97	
		1,00	0,42	0,74	0,76	0,78	0,83	1,13	1,28	1,45	1,61	1,97	1,97	
	u [mm]	40	-	-	-	-	8,0	8,0	8,0	8,0	8,0	10,0	10,0	
		50	-	-	-	-	10,0	10,0	10,0	10,0	10,0	10,0	12,5	12,5
		60	-	-	-	-	12,0	12,0	12,0	12,0	12,0	12,0	15,0	15,0
		80	-	-	-	-	16,0	16,0	16,0	16,0	16,0	16,0	20,0	20,0
		100	-	-	-	-	20,0	20,0	20,0	20,0	20,0	20,0	25,0	25,0
		120	-	-	-	-	24,0	24,0	24,0	24,0	24,0	24,0	30,0	30,0
		≥ 160	-	-	-	-	32,0	32,0	32,0	32,0	32,0	32,0	40,0	40,0

Note

1. Above mentioned values are characteristic values
2. To determine the design value we advise to apply a material factor of $\gamma_m = 1,33$.
3. You can find further information and calculation examples on page 10.1.7